

Pneumatics

Basic level

FESTO

Workbook
TP 101



With CD-ROM

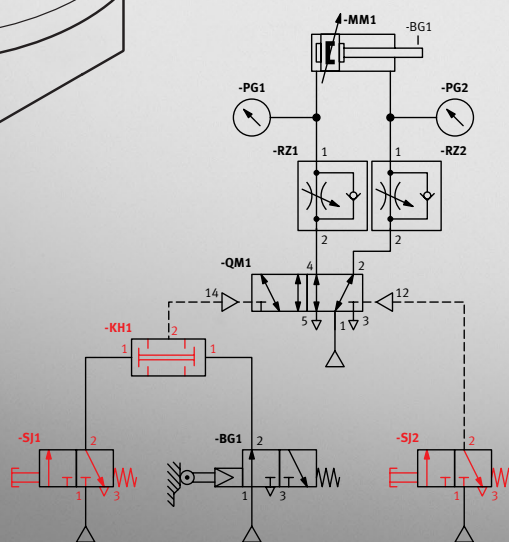
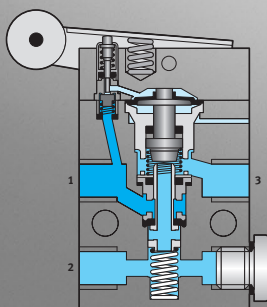
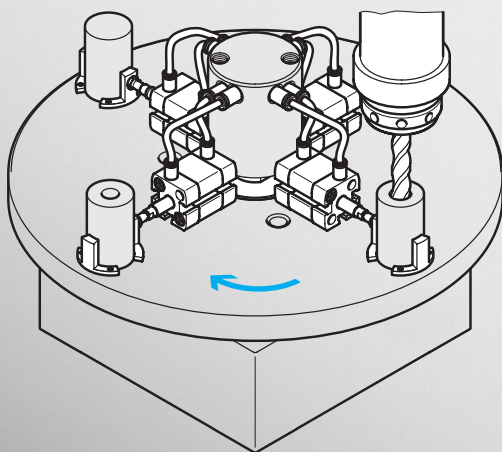

Order no.: 541088
Revision level: 04/2016
Authors: Wolfgang Haring, Michel Metzger, Ralph-Christoph Weber
Editor: Frank Ebel
Graphics: Doris Schwarzenberger
Layout: 06/2016, Frank Ebel

© Festo Didactic SE, Rechbergstr. 3, 73770 Denkendorf, Germany, 2016

All rights reserved.



+49 711 3467-0



www.festo-didactic.com



+49 711 34754-88500



did@festo.com

The purchaser shall receive a single right of use that is non-exclusive, non-time-limited and limited geographically to the purchaser's site/location as follows.

- The purchaser shall be entitled to use the contents of the documentation to train his staff at the purchaser's location and shall also be entitled to use parts of the contents of the documentation to create his own training documentation for the training of his staff at the purchaser's location with acknowledgement of source, and to make copies for this purpose. In the case of schools/technical colleges and training centers, the right of use shall also include use by school pupils, college students and trainees at the purchaser's location for teaching purposes.
- The right of use shall in all cases exclude the right to publish any content or make it available for use on intranet, Internet and LMS platforms and databases such as Moodle, which allow access by a wide variety of users, including those outside of the purchaser's location.
- Entitlement to other rights relating to duplication, copies, adaptations, translations, microfilming and transfer to, as well as storage and processing in electronic systems, either in whole or in part, shall require the prior consent of Festo Didactic.

Note

Wherever teachers, trainees etc. are referred to in the masculine form in this manual, the feminine form is, of course, also implied. The use of a single gender form is not intended as gender-specific discrimination, but simply to aid readability and comprehension of the document and the formulations used.

Contents

Intended use _____	V
Preface _____	VI
Introduction _____	IX
Work and safety instructions _____	X
Pneumatics training package (TP 100) _____	XIII
Training aims for the basic level (TP 101) _____	XIV
Allocation of learning objectives to exercises _____	XV
Equipment set for the basic level (TP 101) _____	XVII
Allocation of components to exercises _____	XX
Notes for the teacher/instructor _____	XXI
Structure of the exercises _____	XXII
Reference designations of the devices _____	XXIII
Contents of the CD-ROM _____	XXIII

Exercises and solutions

Exercise 1: Pressing cheeses.....	3
Exercise 2: Run-on brake on a drive shaft	11
Exercise 3: Clamping boards on a saw machine	17
Exercise 4: Loading packages	23
Exercise 5: Stopping milk bottles.....	33
Exercise 6: Opening and closing a supply pipe	39
Exercise 7: Shutting off using a quick power lockout.....	47
Exercise 8: Actuating a shut-off device	53
Exercise 9: Expanding a control system to enable cheese pressing	61
Exercise 10: Clamping a workpiece	69
Exercise 11: Loading mesh baskets	77
Exercise 12: Actuating a sliding door	83
Exercise 13: Feeding in wooden boards	91
Exercise 14: Pressing drinks cans	97
Exercise 15: Stamping valve housings	105
Exercise 16: Mounting locking clips	113
Exercise 17: Labeling paint buckets	121
Exercise 18: Cleaning workpieces	129
Exercise 19: Pressing product labels into place	137

Exercises and worksheets

Exercise 1: Pressing cheeses..... 3
Exercise 2: Run-on brake on a drive shaft 11
Exercise 3: Clamping boards on a saw machine 17
Exercise 4: Loading packages 23
Exercise 5: Stopping milk bottles..... 33
Exercise 6: Opening and closing a supply pipe 39
Exercise 7: Shutting off using a quick power lockout..... 47
Exercise 8: Actuating a shut-off device 53
Exercise 9: Expanding a control system to enable cheese pressing 61
Exercise 10: Clamping a workpiece 69
Exercise 11: Loading mesh baskets 77
Exercise 12: Actuating a sliding door 83
Exercise 13: Feeding in wooden boards 91
Exercise 14: Pressing drinks cans 97
Exercise 15: Stamping valve housings 105
Exercise 16: Mounting locking clips 113
Exercise 17: Labeling paint buckets 121
Exercise 18: Cleaning workpieces 129
Exercise 19: Pressing product labels into place 137

Nur für den privaten Gebrauch For private use only Solo para uso privado Usage privé uniquement

Nur für den privaten Gebrauch For private use only Solo para uso privado Usage privé uniquement

Intended use

The training package for basic level pneumatics may only be used:

- For its intended purpose in teaching and training applications
- When its safety functions are in perfect condition

The components included in the training package are designed in accordance with the current state of the art and recognized safety rules. However, life and limb of the user and third parties may be endangered and the components may be impaired if it is used incorrectly.

The Festo Didactic learning system has been developed and produced exclusively for basic and further training in the field of automation technology. The training company and/or instructors must ensure that all trainees observe the safety precautions described in this workbook.

Festo Didactic hereby excludes any and all liability for damages suffered by trainees, the training company and/or any third parties, which occur during use of the equipment sets in situations that serve any purpose other than training and/or vocational education, unless such damages have been caused by Festo Didactic due to malicious intent or gross negligence.

Preface

Festo Didactic's learning system for automation and technology is geared towards various educational backgrounds and vocational requirements. The learning system is therefore broken down as follows:

- Technology-oriented training packages
- Mechatronics and factory automation
- Process automation and closed-loop control technology
- Mobile robotics
- Hybrid learning factories

The learning system for automation and technology is continuously updated and expanded in accordance with developments in the field of education, as well as actual professional practice.

The training packages deal with various technologies including pneumatics, electropneumatics, closed-loop pneumatics, hydraulics, electrohydraulics, proportional hydraulics, closed-loop hydraulics, mobile hydraulics, programmable logic controllers, sensor technology, electrical engineering, electronics and electric drives.



The modular design of the learning system allows for applications that go above and beyond the limitations of the individual training packages. For example, PLC control of pneumatic, hydraulic and electric drives is possible.

All training packages feature the following elements:

- Hardware
- Media
- Seminars

Hardware

The hardware in the training packages is comprised of industrial components and systems that are specially designed for training purposes. The components contained in the training packages are specifically designed and selected for the projects in the accompanying media.

Media

The media provided for the individual topics consist of a mixture of teachware and software. The teachware includes:

- Technical literature and textbooks (standard works for teaching basic knowledge)
- Workbooks (practical exercises with supplementary instructions and sample solutions)
- Dictionaries, manuals and technical books (for technical information on groups of topics for further exploration)
- Transparency sets and videos (for easy-to-follow, dynamic instruction)
- Posters (for presenting information in a clear-cut way)

The following software programs are available:

- Digital training programs (learning content specifically designed for virtual training)
- Simulation software
- Visualization software
- Software for acquiring measurement data
- Project engineering and design engineering software
- Programming software for programmable logic controllers

The teaching and learning media are available in several languages. They are intended for use in classroom instruction, but are also suitable for self-study.

Workbook license types

We offer the following three license types for workbooks:

- **Home use license**
For personal use. You order the workbook online as a PDF file. All of the workbook's pages are watermarked. You can save the PDF file to your PC, print it out and edit it. The multimedia CD-ROM is not included.
- **Campus license**
This is the standard option for commercial use. You order a printed version of the workbook with a multimedia CD-ROM in the language of your choice. The files included on the multimedia CD-ROM can be saved to your PC, printed out and edited.

- **Enterprise license**

For large companies and educational institutions with multiple locations. You order either:

- A printed version of the workbook in the language of your choice including a multimedia CD-ROM with multilingual content

or

- A multimedia CD-ROM with multilingual content.

The files included on the multimedia CD-ROM can be saved to your PC, printed out and edited.

Note

The full rights of use are in compliance with the stipulations included in the legal notice of the purchased workbook.

Do you have tips or suggestions for improving this workbook?

If so, please inform us by e-mail at did@festo.com.

The authors and Festo Didactic look forward to your comments.

Seminars

A wide range of seminars covering the contents of the training packages round off the system for basic and further training.

Introduction

This workbook is part of the learning system for automation technology from Festo Didactic. The system provides a solid basis for practice-oriented basic and further training. Training package TP 100 contains only purely pneumatic control systems.

The TP 101 basic level is suitable for fundamental training in the field of pneumatic control technology. It provides an understanding of basic physical principles of pneumatics, as well as the function and use of pneumatic components. Simple pneumatic control systems can be set up using the equipment set.

The TP 102 advanced level is targeted at further training in the field of pneumatic control technology. The equipment set can be used to build extensive combinational circuits with input and output signal connections, as well as control systems with sequencer modules.

Technical prerequisites for setting up the control systems include:

- A Learnline or Learntop-S workstation equipped with a Festo Didactic profile plate. The profile plate has 14 parallel T-slots at 50 mm intervals.
- A portable, sound-insulated compressor (230 V, max. 800 kPa = 8 bar) is used to supply compressed air.

The working pressure should not exceed $p = 600$ kPa (6 bar).

Ideal operating safety can be achieved by operating the control system at a working pressure of $p = 500$ kPa (5 bar) without oil.

The complete control systems for all 19 exercises are built using the TP 101 basic level equipment set. The theoretical fundamentals for understanding the exercises listed in this workbook are included in the textbook entitled:

- Fundamentals of pneumatics and electropneumatics

Data sheets for the individual components are also available (cylinders, valves, measuring devices, etc.).

Work and safety instructions



General

- Trainees should only work with the circuits under the supervision of an instructor.
- Electrical devices (e.g. power supply units, compressors and hydraulic units) may only be operated in training rooms that are equipped with residual current devices (RCDs).
- Observe the specifications included in the technical data for the individual components, and in particular all safety instructions!
- Care must be taken to avoid malfunctions that may impair safety.
- Wear your personal protective equipment (safety goggles, safety shoes) when working on circuits.

Mechanical safety

- Switch off the power supply!
 - Switch off working and control power before working on the circuit.
 - Only reach into the setup when it is at a complete standstill.
 - Be aware of the potential overtravel times for the drives.
- Mount all of the components on the profile plate securely.
- Make sure that limit valves are not actuated from the front.
- Risk of injury during troubleshooting!
 - Use a tool such as a screwdriver to actuate the limit valves.
- Set all components up in a way that makes it easy to activate the switches and disconnectors.
- Follow the instructions regarding positioning of the components.

Electrical safety

- Disconnect from all sources of electrical power!
 - Switch off the power supply before working on the circuit.
 - Please note that electrical energy may be stored in individual components.
 - Further information on this issue is available in the data sheets and operating instructions included with the components.
- Use protective extra-low voltage only: max. 24 V DC.
- Establishing and disconnecting electrical connections
 - Electrical connections may only be established in the absence of voltage.
 - Electrical connections may only be disconnected in the absence of voltage.

- Always use connecting cables with safety plugs for electrical connections.
- When laying connecting cables, make sure they are not kinked or pinched.
- Do not lay cables over hot surfaces.
 - Hot surfaces are marked with a corresponding warning symbol.
- Make sure that connecting cables are not subjected to continuous tensile loads.
- Always pull on the safety plug when disconnecting connecting cables; never pull the cable.

Pneumatic safety

- Depressurize the system!
 - Switch off the compressed air supply before working on the circuit.
 - Check the system with pressure gauges to make sure that the entire circuit is fully depressurized.
 - Please note that energy may be stored in air reservoirs.
Further information on this issue is available in the data sheets and operating instructions included with the components.
- Do not exceed the maximum permissible pressure of 600 kPa (6 bar).
- Do not switch on the compressed air until all tubing connections have been established and secured.
- Do not disconnect tubing while under pressure.
- Risk of injury when switching on the compressed air!
Cylinders may advance and retract automatically.
- Risk of accident due to advancing cylinders!
 - Always position pneumatic cylinders so that the piston rod's working space is unobstructed over the entire stroke range.
 - Make sure that the piston rod cannot collide with any rigid components of the setup.
- Risk of accident due to tubing slipping off!
 - Use the shortest possible tubing connections.
 - If tubing slips off:
Switch off the compressed air supply immediately.
- Pneumatic circuit setup:
Connect the devices using plastic tubing with an outside diameter of 4 or 6 mm. Push the tubing into the push-in connector as far as it will go.
- Switch the compressed air supply off before dismantling the circuit.
- Dismantling the pneumatic circuit
Press the blue release ring down so that the tube can be pulled out.

- Noise due to escaping compressed air
 - Noise caused by escaping compressed air may damage your hearing. Reduce the noise by using mufflers, or wear hearing protection if the noise cannot be avoided.
 - All of the exhaust ports for the components included in the equipment set are equipped with mufflers. Do not remove these mufflers.

Mounting technology

The mounting boards for the devices are equipped with mounting variant A, B, C or D:

- Variant A, snap-in system
Lightweight devices that cannot be subjected to loads (e.g. directional control valves). Simply clip the devices into the slots on the profile plate. Release the devices by turning the blue lever.
- Variant B, rotary system
Devices with medium load capacity (e.g. drives). These devices are clamped to the profile plate with T-head bolts. The blue knurled nut is used for clamping and loosening.
- Variant C, screw system
For devices that will be subject to heavy loads and that will rarely need to be removed from the profile plate (e.g. on-off valve with filter regulating valve). The devices are secured with socket head screws and T-head nuts.
- Variant D, plug-in system
Lightweight devices with lock pins that cannot be subjected to loads (e.g. indicator units). These are secured using plug-in adapters.

Necessary accessories

A stopwatch is required to assess the constructed circuits. The stopwatch is used for the following tasks:

- To ensure that the advancing and retracting times of the cylinders in one-way flow control valves comply with the specifications
- To set pneumatic timers

Pneumatics training package (TP 100)

The TP 100 training package consists of a multitude of individual training materials and seminars. The subject matter of this package is strictly pneumatic control systems. Individual elements included in training package TP 100 may also be included in other packages.

Important TP 100 components

- Permanent workstation with Festo Didactic profile plate
- Equipment set or individual components (e.g. cylinders, directional control valves, preset counters, stepper modules, logic components, pneumatic proximity sensors)
- Optional training aids (e.g. optical displays, 5/3-way valve, pulling/pushing load)
- Complete set of laboratory equipment

Media

The teachware for the TP 100 training package consists of a textbook and workbooks. The textbook provides basic physical and technical knowledge regarding pneumatics and electropneumatics. The workbooks include exercise sheets for each exercise, the solutions to each individual worksheet and a CD-ROM. A set of ready-to-use exercise sheets and worksheets is included in each workbook for all of the exercises.

Data sheets for the hardware components are supplied with the equipment set.

Media	
Text book	Fundamentals of pneumatics and electropneumatics
Workbooks	Pneumatics, Basic level (TP 101) Pneumatics, Advanced level (TP 102)
Optional teachware	Basic pneumatic control systems – practical knowledge Simulation software FluidSIM® Pneumatics WBT Pneumatics Set of cutaway models with storage case

Available software for use in combination with training package TP 100 includes FluidSIM® P and the Pneumatics digital training program. FluidSIM® P aids with the preparation of the lessons. Pneumatic control systems can be set up and simulated. The Pneumatics digital training program provides knowledge regarding the fundamentals of pneumatic control systems. With the help of examples based on actual industrial practice, learners work through the fundamentals of pneumatics and become familiar with components used in pneumatic systems.

Further training materials can be found in our catalogs and on the Internet. The learning system for automation and technology is continuously updated and expanded. The transparency sets, videos, CD-ROMs, DVDs and textbooks are available in several languages.

Training aims for the basic level (TP 101)

■ Components

- Become familiar with the setup and function of a single-acting cylinder.
- Become familiar with the setup and function of a double-acting cylinder.
- Become familiar with the setup and function of a 3/2-way valve.
- Become familiar with the setup and function of a 5/2-way valve.
- Become familiar with the function of a pneumatically activated 5/2-way valve.
- Become familiar with the setup and function of a magnetic proximity sensor.
- Become familiar with the setup and function of a pressure sequence valve.
- Become familiar with the setup and function of a pressure regulator.
- Become familiar with the setup and function of a pneumatic timer.

■ Circuits

- Be able to recognize and sketch the various types of actuation used for directional control valves.
- Be able to explain and set up direct actuation.
- Be able to analyze and evaluate circuits.
- Be able to explain and set up indirect actuation.
- Become familiar with the difference between a signaling element and a control element.
- Be able to distinguish between flow control methods and use them in accordance with specifications.
- Become familiar with a way of storing signals in pneumatic control systems.
- Become familiar with the logic operations AND/OR/NOT and be able to implement them.
- Be able to explain and set up latching circuits.
- Become familiar with a way of sensing the end positions of cylinders.
- Be able to combine logic operations.
- Be able to distinguish between 5/2-way valves, and select and use them in accordance with specifications.
- Be able to develop existing circuits further.
- Be able to set up pressure-dependent control systems.
- Be able to analyze existing circuits and optimize them in accordance with specifications.
- Be able to set up circuits with oscillating movements.
- Be able to use pneumatic timers in accordance with parameters.
- Be able to set up time-dependent control systems.
- Be able to create the GRAFCET for a process.
- Be able to analyze and set up circuits with two cylinders.

■ Measurements, settings and calculations

- Be able to measure the pressure in pneumatic control systems.
- Be able to set the advancing and retracting speeds of cylinders.

Allocation of learning objectives to exercises

Exercise	1	2	3	4	5	6	7	8	9	10	11	12	13	14	15	16	17	18	19	
Training aims																				
Become familiar with the setup and function of a single-acting cylinder.	•	•	•																	
Become familiar with the setup and function of a 3/2-way valve.	•	•	•																	
Be able to recognize and sketch the various types of actuation used for directional control valves.	•	•	•																	
Be able to explain and set up direct actuation.	•	•	•	•																
Be able to analyze and evaluate circuits.			•													•				
Become familiar with the setup and function of a double-acting cylinder.				•																
Become familiar with the setup and function of a 5/2-way valve.				•	•															
Be able to explain and set up indirect actuation.					•					•										
Become familiar with the difference between a signaling element and a control element.					•															
Be able to measure the pressure in pneumatic control systems.						•														
Be able to distinguish between flow control methods and use them in accordance with specifications.						•	•													
Be able to set the advancing and retracting speeds of cylinders.							•	•												
Become familiar with a way of storing signals in pneumatic control systems.								•		•										

Exercise	1	2	3	4	5	6	7	8	9	10	11	12	13	14	15	16	17	18	19
Learning objectives																			
Become familiar with the logic operations AND/OR/NOT and be able to implement them.									•	•	•	•	•						
Be able to explain and set up latching circuits.											•								
Become familiar with a way of sensing the end positions of cylinders.											•								
Be able to combine logic operations.												•	•						
Become familiar with the setup and function of a magnetic proximity sensor.												•							
Be able to distinguish between 5/2-way valves, and select and use them in accordance with specifications.												•							
Be able to develop existing circuits further.									•				•						
Become familiar with the setup and function of a pressure sequence valve.														•					
Be able to set up pressure-dependent control systems.														•	•	•	•		
Become familiar with the setup and function of a pressure regulator.															•				
Become familiar with the setup and function of a pneumatic timer.																		•	
Be able to create the GRAFCET for a process.																		•	
Be able to set up circuits with oscillating movements.																			•
Be able to use pneumatic timers in accordance with parameters.																			•
Be able to analyze and set up circuits with two cylinders.																			•

Equipment set for the basic level (TP 101)

This equipment set has been put together for basic training in the field of pneumatic control technology. It includes all of the elements necessary for achieving the specified learning objectives, and can be supplemented with any other equipment sets.

A profile plate and a source of compressed air are also required in order to set up functional control systems.

■ Equipment set for the basic level (TP 101), order no. 540710

Quantity	Designation	Order no.
2	3/2-way valve with pushbutton actuator, normally closed	152860
1	3/2-way valve with pushbutton actuator, normally open	152861
1	3/2-way valve with selector switch, normally closed	152863
2	3/2-way roller-actuated valve, normally closed	152866
1	3/2-way valve, pneumatically actuated, one side	576302
1	5/2-way valve with selector switch	152862
1	5/2-way valve, pneumatically actuated, one side	576307
3	5/2-way bistable valve, pneumatically actuated, both sides	576303
1	Single-acting cylinder	152887
1	Double-acting cylinder	152888
2	Proximity sensor, pneumatic, with cylinder attachment	2764815
2	One-way flow control valve	193967
1	Quick-exhaust valve	539772
2	Pressure gauge	152865
1	Pressure regulator with gauge	539756
1	Pressure sequence valve	152884
1	OR valve	539771
2	AND valve	539770
1	Pneumatic timer, normally closed	540694
1	On-off valve with filter regulating valve	540691
1	Distributor block	152896
10	Push-in sleeve	153251
10	T-plug connector	153128
2	Plastic tubing, 4 x 0.75, silver, 10 m	151496

■ Equipment set symbols

Component	Symbol	Component	Symbol
3/2-way valve with pushbutton actuator, normally closed		Single-acting cylinder	
3/2-way valve with pushbutton actuator, normally open		Double-acting cylinder	
3/2-way valve with selector switch		Pneumatic proximity sensor	
3/2-way roller-actuated valve, normally closed		One-way flow control valve	
3/2-way valve, pneumatically actuated, one side		Quick-exhaust valve	
5/2-way valve with selector switch		Pressure gauge	
OR valve		Pressure regulator with gauge	
AND valve		Pneumatic timer, normally closed	

Component	Symbol
5/2-way valve, pneumatically actuated, one side	
5/2-way bistable valve, pneumatically actuated, both sides	
Pressure sequence valve	
On-off valve with filter regulating valve	
Distributor block	

Allocation of components to exercises

Exercise	1	2	3	4	5	6	7	8	9	10	11	12	13	14	15	16	17	18	19
Component																			
Cylinder, single-acting	1	1	1						1										1
Cylinder, double-acting				1	1	1	1	1		1	1	1	1	1	1	1	1	1	1
One-way flow control valve						2	1	1		2	2	2	2	2	2	2	1	2	2
Quick-exhaust valve								1									1		
Pressure gauge						2		1		2							1		
3/2-way valve with pushbutton actuator, normally closed	1							2	2	2	1	2	1	2	2	1	1	1	1
3/2-way valve with pushbutton actuator, normally open		1								1									
3/2-way valve with selector switch, normally closed			1		1								1						
3/2-way roller-actuated valve, normally closed										1			1					1	1
Pneumatic proximity sensor												2	2	2	1	2	2	2	2
3/2-way pneumatic valve											1					1			
3/2-way pneumatic bistable valve																		1	1
5/2-way valve with selector switch				1		1	1												
5/2-way pneumatic valve					1					1	1	1							
5/2-way pneumatic bistable valve								1					1	1	1	1	1	1	1
OR valve									1		1	1		1				1	
AND valve										1		2	2	1	1	2	1		2
Pressure sequence valve														1	1	1			1
Pressure regulator with gauge														1	2	1	1		
Pneumatic timer, normally closed																	1	1	
Distributor block	1	1	1	1	1	1	1	1	1	1	1	1	1	1	1	1	1	1	1
On-off valve with filter regulating valve	1	1	1	1	1	1	1	1	1	1	1	1	1	1	1	1	1	1	1

Nur für den privaten Gebrauch For private use only Solo para uso privado Usage privé uniquement

Nur für den privaten Gebrauch For private use only Solo para uso privado Usage privé uniquement

Notes for the teacher/instructor

Training aims

The basic learning objectives for the book of exercises are the systematic drafting of circuit diagrams, as well as the practical setup of the control system on the profile plate. This direct interaction involving both theory and practice ensures faster progress and longer-lasting learning. The more specific training aims are documented in the matrix. Concrete, individual training aims are assigned to each exercise.

Required time

The time required for working through the exercises depends on the student's previous knowledge of the subject matter. For a skilled laborer in the field of metalworking or electrical installation, the time required is approx. 2 weeks. For a technician or engineer, it is approx. 1 week.

Equipment set components

The textbook, workbook and equipment set are designed to be used together. All 19 exercises can be completed using the components from one TP 101 equipment set.

Each exercise can be set up on a profile plate with a width of at least 700 mm.

Standards

The following standards apply to this workbook:

- | | |
|-------------|---|
| ISO 1219-1: | Fluid power systems and components – Graphic symbols and circuit diagrams – Symbols |
| EN 81346-2: | Industrial systems, installations and equipment and industrial products – Structuring principles and reference designations |

Identification of solutions

Solutions and additions in graphics or diagrams appear in red.

Identification in the worksheets

Texts that require completion are identified with blank lines or gray table cells.

Graphics and diagrams that require completion include a grid.

Training notes

This section provides additional information regarding the individual components and the completed control systems. These notes are not included in the worksheets.

Solutions

The solutions provided in this workbook are the results of test measurements. The results of your measurements may deviate from these.

Fields of learning

The allocation of the field of learning offered by vocational schools to the subject matter of “fluid power” is provided below for selected vocational apprenticeships.

Vocational apprenticeship	Topic
Electronics engineer for automation technology	Analyzing and adapting control systems
	Systems implementation and safety testing
Industrial mechanic	Installing and commissioning control systems
Mechatronics technician	Examination of the flow of energy and information in electrical, pneumatic and hydraulic assemblies
	Implementation of mechatronic subsystems

Structure of the exercises

All 19 exercises have the same structure and are broken down into:

- Title
- Training aims
- Description of the problem
- Layout
- Parameters
- Work assignments
- Work aids
- Worksheets

The workbook includes the solution for each of the worksheets for all 19 exercises.

Reference designations of the devices

The reference designations in the circuit diagrams are in compliance with EN 81346-2:2010-05, Industrial systems, installations and equipment and industrial products – Structuring principles and reference designations – Part 2: Classification of objects and codes for classes. The product-related aspect of the devices is taken into consideration, which is why all reference designations begin with a dash. Codes are assigned depending on the device. If several devices within a circuit have the same code, consecutive numbers are assigned to them as well.

Cylinders:	-MM1, -MM2...
Valves:	-QM1, -QM2, -KH1, -KH2, -RM1, -RZ1, ...
Sensors:	-BG1, -BG2, -BF1, -BP1, ...
Signal inputs:	-SF1, -SF2, -SJ1, -SJ2, ...
Accessories:	-AZ1, -AZ2, -XM1, -XM2, -PG1, ...

Contents of the CD-ROM

For the Campus and Enterprise license types, a multimedia CD-ROM is supplied with the workbook. The entire workbook is included on the CD-ROM as a PDF file. The CD-ROM also provides you with additional media.

The CD-ROM includes the following folders:

- Operating instructions
- Images
- FluidSIM® circuit diagrams
- Presentations
- Videos

Operating instructions

Operating instructions are provided for various devices included in the training package. These instructions are helpful when using and commissioning the devices.

Images

Photos and graphics of components and industrial applications are provided. These can be used to illustrate individual tasks or to supplement project presentations.

FluidSIM® circuit diagrams

The FluidSIM® circuit diagrams for all of the exercises included in the training package are contained in this directory.

Presentations

This directory contains short presentations for the devices included in the training package. These can be used to create project presentations, for example.

Videos

Finally, there are several short videos of industrial applications in their actual environments.

Contents

Exercises and solutions

Exercise 1: Pressing cheeses.....	3
Exercise 2: Run-on brake on a drive shaft	11
Exercise 3: Clamping boards on a saw machine	17
Exercise 4: Loading packages	23
Exercise 5: Stopping milk bottles.....	33
Exercise 6: Opening and closing a supply pipe	39
Exercise 7: Shutting off using a quick power lockout.....	47
Exercise 8: Actuating a shut-off device	53
Exercise 9: Expanding a control system to enable cheese pressing	61
Exercise 10: Clamping a workpiece	69
Exercise 11: Loading mesh baskets	77
Exercise 12: Actuating a sliding door	83
Exercise 13: Feeding in wooden boards	91
Exercise 14: Pressing drinks cans	97
Exercise 15: Stamping valve housings	105
Exercise 16: Mounting locking clips	113
Exercise 17: Labeling paint buckets	121
Exercise 18: Cleaning workpieces	129
Exercise 19: Pressing product labels into place	137

Nur für den privaten Gebrauch For private use only Solo para uso privado Usage privé uniquement

Nur für den privaten Gebrauch For private use only Solo para uso privado Usage privé uniquement

Exercise 1: Pressing cheeses

■ Training aims

After completing this exercise, you will:

- Be familiar with the setup and function of a single-acting cylinder.
- Be able to calculate the piston force of a single-acting cylinder.
- Be familiar with the setup and function of a 3/2-way valve, normally closed.
- Be able to recognize and sketch the various types of actuation used for directional control valves.
- Be able to explain and set up direct actuation.

■ Description of the problem

In cheese manufacturing, pneumatic cylinders are used to press the cheese into molds. Develop a control system that can be used to carry out this process.

■ Layout

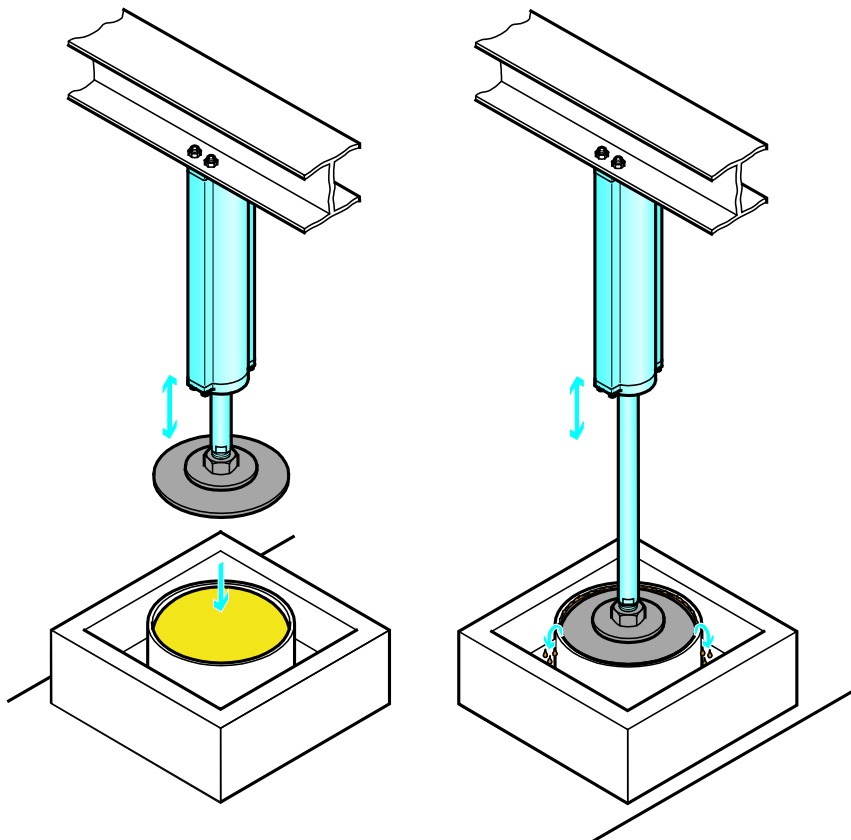

Cheese manufacturing – press

■ Description of the process

1. The cheese is inserted in the press by hand.
2. When a pushbutton actuator is pressed, the piston rod on the cylinder advances and presses the lid onto the mold.
3. The pushbutton actuator is held down until the pressing procedure is complete.
4. When the pushbutton actuator is released, the piston rod retracts again, allowing access to the mold.
5. The cheese can then be removed.

■ Parameters

- Use a single-acting cylinder.
- The cylinder must be pneumatically controlled using a manually operated valve.

■ Work assignments

1. Describe the setup and function of a single-acting cylinder.
2. Calculate the piston force of a single-acting cylinder.
3. Describe the setup and function of a 3/2-way valve, normally closed.
4. Complete the pneumatic circuit diagram for the press.
5. Create an equipment list.
6. Set up the control system.
7. Check the setup of the control system.
8. Describe the working sequence for the control system.

■ Work aids

- Books of tables
- Textbook: Fundamentals of pneumatics and electropneumatics
- Component data sheets
- FluidSIM® P design and simulation software
- WBT: Pneumatics



Safety instructions

- For this exercise, limit the pressure on the filter regulating valve (service unit) to max. 350 kPa (3.5 bar).
- If tubing slips off: switch off the compressed air supply immediately.

1. Setup and function of a single-acting cylinder

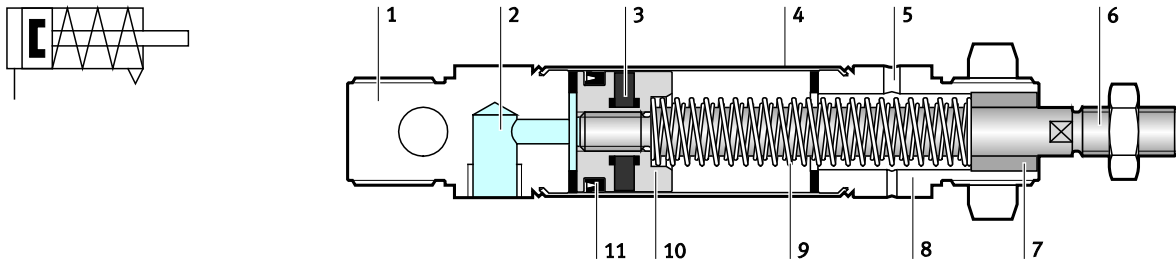

Single-acting cylinder – circuit symbol and cutaway view

- a) Compare the circuit symbol shown above with the schematic diagram of the single-acting cylinder. Determine whether or not the two diagrams match.

The two diagrams match. The diagram shows a single-acting cylinder. In the normal position, the piston rod is kept retracted by the spring return. A permanent magnet is mounted on the piston for position sensing purposes.

- b) Assign the corresponding number to each component in the drawing above.

Component	Designation
4	Cylinder barrel
1	End cap
8	Bearing cap
6	Piston rod
10	Piston
3	Ring magnet
11	Piston seal
9	Spring return
2	Compressed air supply port
7	Guide bushing
5	Exhaust hole

- c) Describe the setup and function of a single-acting cylinder.

The compressed air flows into the cylinder's piston chamber. Pressure is built up in the chamber and force is applied to the surface of the piston as a result. When this force exceeds the static friction, the piston advances. The full operating pressure is not reached until the piston is fully advanced.

When the pressure drops, the built-in spring return pushes the piston back to its start position. The spring force is not great enough to move heavy loads on the piston rod. As such, single-acting cylinders only work in one direction.

2. Calculating the piston force of a single-acting cylinder

Information

The theoretical piston force is calculated using the following formula:

$$F_{th} = A \cdot p$$

F_{th}	Theoretical piston force (N)	A	Useful piston area (m ²)
			$(\frac{D^2 \cdot \pi}{4})$

p	Working pressure (Pa)	D	Cylinder diameter (m)
-----	-----------------------	-----	-----------------------

In practice, it is the effective piston force F_{eff} that is important. When calculating this, the frictional resistance must be taken into consideration. Under normal operating conditions (pressure range: 400 to 800 kPa/4 to 8 bar), the friction forces (F_R) can be assumed as being approx. 10% of the theoretical piston force.

The effective piston force of a single-acting cylinder is calculated as follows:

$$F_{eff} = A (p - (F_R + F_F))$$

F_{eff}	Effective piston force (N)	F_R	Friction force (approx. 10% of F_{th}) (N)
-----------	----------------------------	-------	---

F_F	Spring return force (N)
-------	-------------------------

- Calculate the effective piston force during the forward stroke for the cylinder in question at a working pressure of 600 kPa (6 bar).

Calculating the piston area and piston force
(Cylinder diameter in m, working pressure in Pa)

$$A = \left(\frac{0.02^2 \cdot 3.14}{4} \right) = 0.000314 \text{ m}^2$$

$$F_{\text{eff}} = 0.9 \cdot A \cdot p - F_{\text{F}}$$

$$F_{\text{eff}} = 0.9 \cdot 0.000314 \text{ m}^2 \cdot 600,000 \text{ Pa} - 13.6 \text{ N}$$

$$F_{\text{eff}} = 169.56 \text{ N} - 13.6 \text{ N} = 155.96 \text{ N}$$

Calculating the piston area and piston force
(Cylinder diameter in cm, working pressure in bar)

$$A = \left(\frac{2^2 \cdot 3.14}{4} \right) = 3.14 \text{ cm}^2$$

$$F_{\text{eff}} = 0.9 \cdot A \cdot p - F_{\text{F}}$$

$$F_{\text{eff}} = 0.9 \cdot 3.14 \text{ cm}^2 \cdot 60 \frac{\text{N}}{\text{cm}^2} - 13.6 \text{ N}$$

$$F_{\text{eff}} = 169.56 \text{ N} - 13.6 \text{ N} = 155.96 \text{ N}$$

Note

Consult the cylinder data sheet for the necessary data.

Training note

For the cylinder in question, the piston diameter is 20 mm and the spring return force is 13.6 N.

3. How a 3/2-way valve, normally closed, works

- Complete the circuit symbol of a manually operated, normally closed 3/2-way valve with spring return.

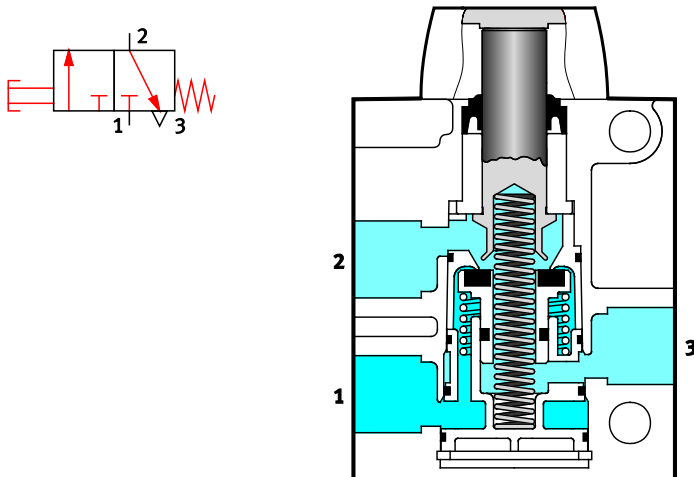

3/2-way valve, manually operated, with spring return, normally closed – circuit symbol and cutaway view

b) Describe how the 3/2-way valve works.

A 3/2-way valve has 3 ports and 2 switching positions. It is shown here in its normal position.

"Normally closed" means that the compressed air cannot flow through the valve. When the pushbutton actuator is pressed, the 3/2-way valve opens up the air flow. The piston chamber of a connected cylinder is pressurized and the piston rod advances.

4. Completing the pneumatic circuit diagram

- Complete the pneumatic circuit diagram for the press. Add any incomplete circuit symbols. Label the individual components and enter the missing port designations.

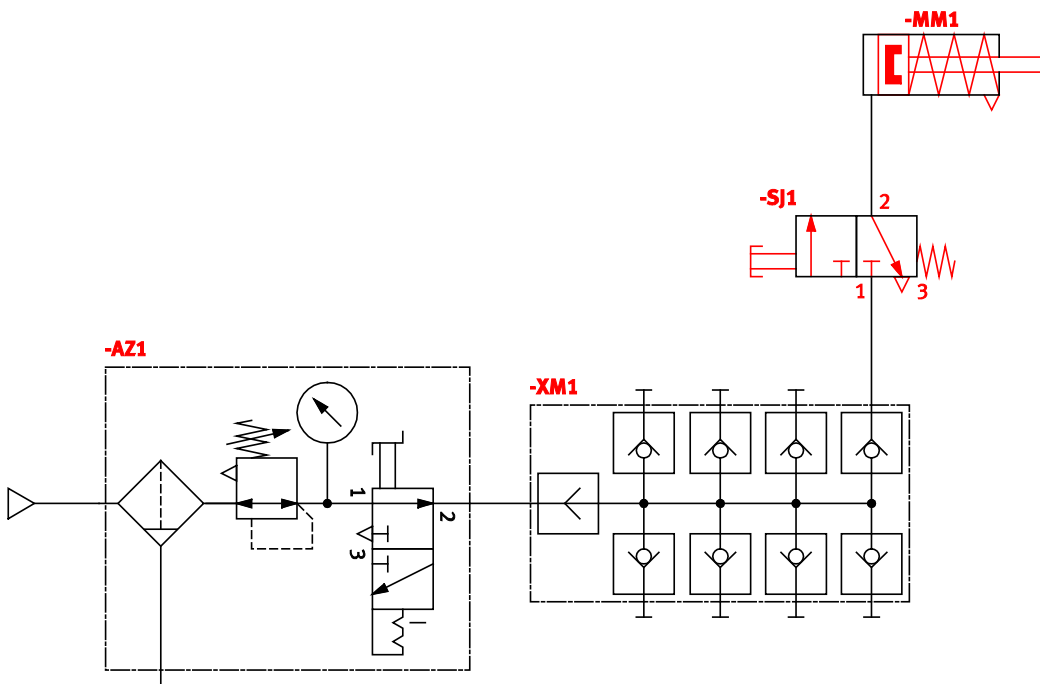

5. Creating the equipment list

- Create the equipment list. Enter the quantity, identification and designation of the required components in the table below.

Quantity	Identification	Designation
1	-MM1	Cylinder, single-acting
1	-SJ1	3/2-way valve with pushbutton actuator, normally closed
1	-XM1	Distributor block
1	-AZ1	On-off valve with filter regulating valve
1	–	Compressed air source

6. Setting up the control system

Observe the following points when setting up the control system:

- Use the circuit diagram.
- Designate the components.
- Lay the compressed air tubing using the shortest routes possible.
- Push the compressed air tubing into the push-in connector as far as it will go.
- Mark the connected compressed air tubing on the circuit diagram.

7. Double-checking the control system setup

Observe the following points when commissioning the control system:

- Check all the tubing connectors.
- For the first test run, reduce the pressure on the filter regulating valve (service unit) to 350 kPa (3.5 bar).
- Switch on the compressed air supply at the service unit.
- Check that the control system is working correctly.
- Increase the pressure to the level specified in the exercise instructions.
- Allow the control system to run through several complete cycles.



Risk of injury when switching on the compressed air!

Cylinders may advance and retract automatically.

Risk of injury if compressed air tubing slips off!

If compressed air tubing slips off, shut off the compressed air supply immediately.

8. Describing the control system sequence

- Describe the individual steps of the control system sequence.

Initial position

In its initial position, the 3/2-way valve -SJ1 is closed. The piston rod on cylinder -MM1 is retracted.

Step 1-2

When the pushbutton actuator for the 3/2-way valve -SJ1 is pressed, compressed air flows into the piston chamber of cylinder -MM1 and the piston rod advances.

Step 2-3

When the pushbutton actuator is released, the 3/2-way valve -SJ1 is exhausted and the piston rod of cylinder -MM1 is pushed back to its initial position by the spring return.

Contents

Exercises and worksheets

Exercise 1: Pressing cheeses.....	3
Exercise 2: Run-on brake on a drive shaft	11
Exercise 3: Clamping boards on a saw machine	17
Exercise 4: Loading packages	23
Exercise 5: Stopping milk bottles.....	33
Exercise 6: Opening and closing a supply pipe	39
Exercise 7: Shutting off using a quick power lockout.....	47
Exercise 8: Actuating a shut-off device	53
Exercise 9: Expanding a control system to enable cheese pressing	61
Exercise 10: Clamping a workpiece	69
Exercise 11: Loading mesh baskets	77
Exercise 12: Actuating a sliding door	83
Exercise 13: Feeding in wooden boards	91
Exercise 14: Pressing drinks cans	97
Exercise 15: Stamping valve housings	105
Exercise 16: Mounting locking clips	113
Exercise 17: Labeling paint buckets	121
Exercise 18: Cleaning workpieces	129
Exercise 19: Pressing product labels into place	137

Nur für den privaten Gebrauch For private use only Solo para uso privado Usage privé uniquement

Nur für den privaten Gebrauch For private use only Solo para uso privado Usage privé uniquement

Exercise 1: Pressing cheeses

■ Training aims

After completing this exercise, you will:

- Be familiar with the setup and function of a single-acting cylinder.
- Be able to calculate the piston force of a single-acting cylinder.
- Be familiar with the setup and function of a 3/2-way valve, normally closed.
- Be able to recognize and sketch the various types of actuation used for directional control valves.
- Be able to explain and set up direct actuation.

■ Description of the problem

In cheese manufacturing, pneumatic cylinders are used to press the cheese into molds. Develop a control system that can be used to carry out this process.

■ Layout

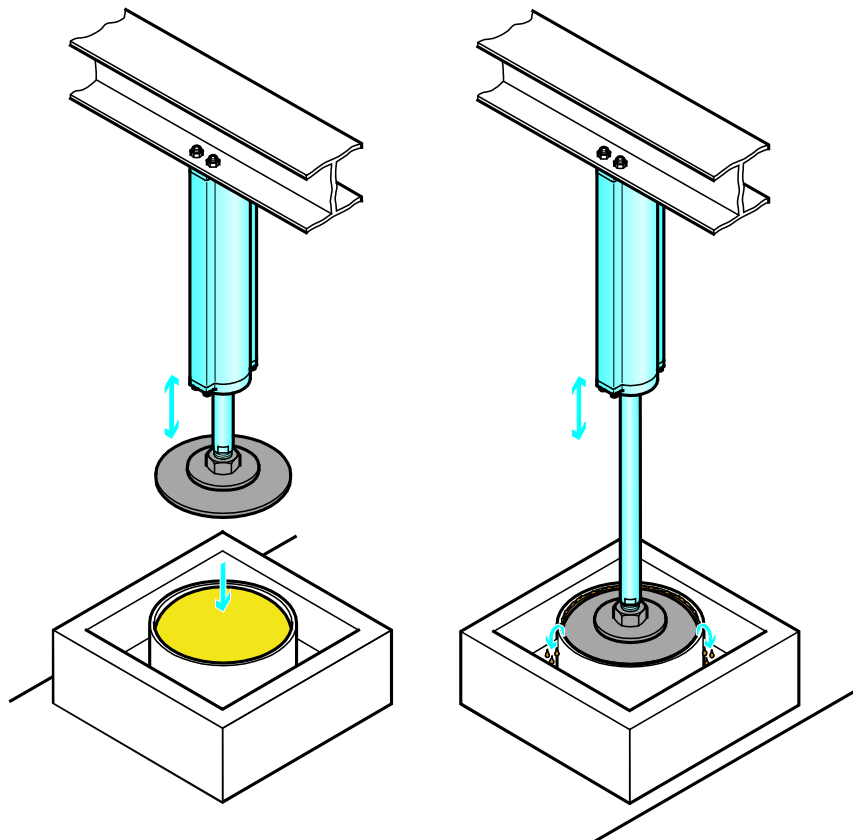

Cheese manufacturing – press

■ Description of the process

1. The cheese is inserted in the press by hand.
2. When a pushbutton actuator is pressed, the piston rod on the cylinder advances and presses the lid onto the mold.
3. The pushbutton actuator is held down until the pressing procedure is complete.
4. When the pushbutton actuator is released, the piston rod retracts again, allowing access to the mold.
5. The cheese can then be removed.

■ Parameters

- Use a single-acting cylinder.
- The cylinder must be pneumatically controlled using a manually operated valve.

■ Work assignments

1. Describe the setup and function of a single-acting cylinder.
2. Calculate the piston force of a single-acting cylinder.
3. Describe the setup and function of a 3/2-way valve, normally closed.
4. Complete the pneumatic circuit diagram for the press.
5. Create an equipment list.
6. Set up the control system.
7. Check the setup of the control system.
8. Describe the working sequence for the control system.

■ Work aids

- Books of tables
- Textbook: Fundamentals of pneumatics and electropneumatics
- Component data sheets
- FluidSIM® P design and simulation software
- WBT: Pneumatics



Safety instructions

- For this exercise, limit the pressure on the filter regulating valve (service unit) to max. 350 kPa (3.5 bar).
- If tubing slips off: switch off the compressed air supply immediately.

1. Setup and function of a single-acting cylinder

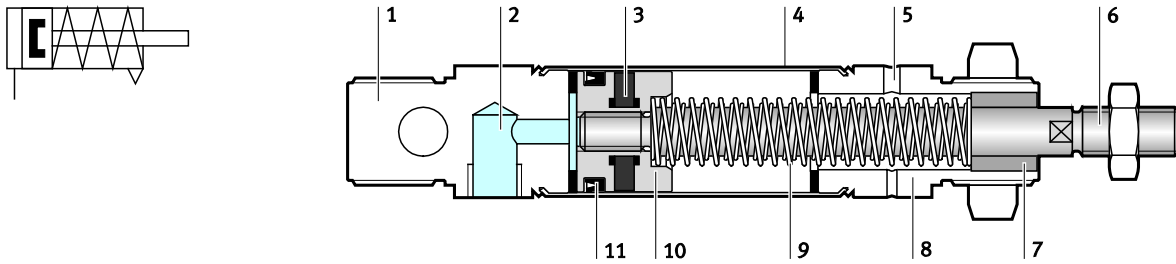

Single-acting cylinder – circuit symbol and cutaway view

- a) Compare the circuit symbol shown above with the schematic diagram of the single-acting cylinder. Determine whether or not the two diagrams match.

- b) Assign the corresponding number to each component in the drawing above.

Component	Designation
	Cylinder barrel
	End cap
	Bearing cap
	Piston rod
	Piston
	Ring magnet
	Piston seal
	Spring return
	Compressed air supply port
	Guide bushing
	Exhaust hole

Nur für den privaten Gebrauch For private use only Solo para uso privado Usage privé uniquement

Nur für den privaten Gebrauch For private use only Solo para uso privado Usage privé uniquement

c) Describe the setup and function of a single-acting cylinder.

2. Calculating the piston force of a single-acting cylinder

Information

The theoretical piston force is calculated using the following formula:

$$F_{th} = A \cdot p$$

F_{th} Theoretical piston force (N) A Useful piston area (m²)
 $(\frac{D^2 \cdot \pi}{4})$

p Working pressure (Pa) D Cylinder diameter (m)

In practice, it is the effective piston force F_{eff} that is important. When calculating this, the frictional resistance must be taken into consideration. Under normal operating conditions (pressure range: 400 to 800 kPa/4 to 8 bar), the friction forces (F_R) can be assumed as being approx. 10% of the theoretical piston force.

The effective piston force of a single-acting cylinder is calculated as follows:

$$F_{eff} = A (p - (F_R + F_F))$$

F_{eff} Effective piston force (N) F_R Friction force (approx. 10% of F_{th}) (N)

F_F Spring return force (N)

- Calculate the effective piston force during the forward stroke for the cylinder in question at a working pressure of 600 kPa (6 bar).

Calculating the piston area and piston force

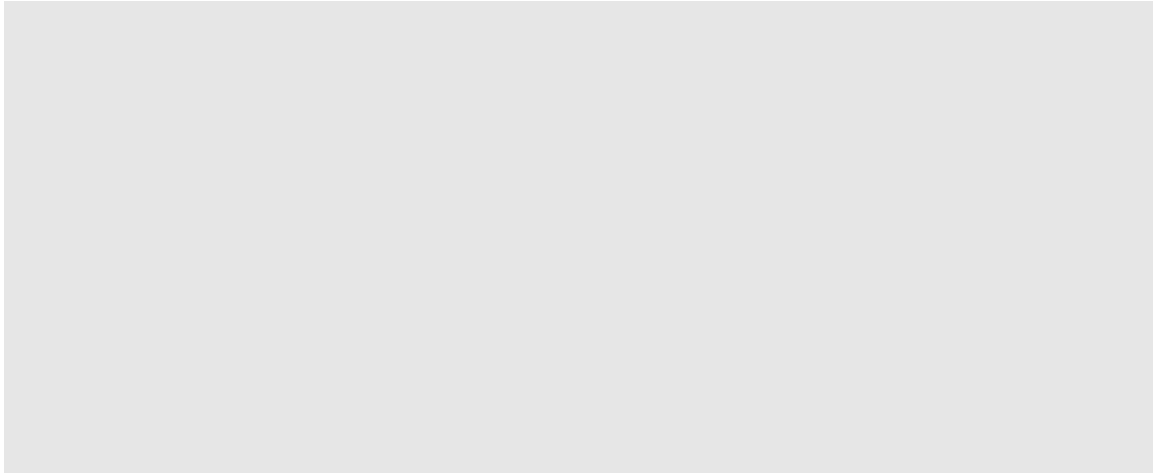

Note

Consult the cylinder data sheet for the necessary data.

3. How a 3/2-way valve, normally closed, works

- a) Complete the circuit symbol of a manually operated, normally closed 3/2-way valve with spring return.

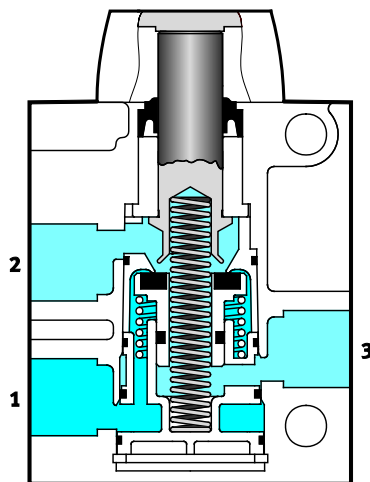
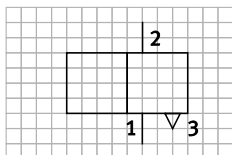

3/2-way valve, manually operated, with spring return, normally closed – circuit symbol and cutaway view

Nur für den privaten Gebrauch For private use only Solo para uso privado Usage privé uniquement

Nur für den privaten Gebrauch For private use only Solo para uso privado Usage privé uniquement

b) Describe how the 3/2-way valve works.

4. Completing the pneumatic circuit diagram

- Complete the pneumatic circuit diagram for the press. Add any incomplete circuit symbols. Label the individual components and enter the missing port designations.

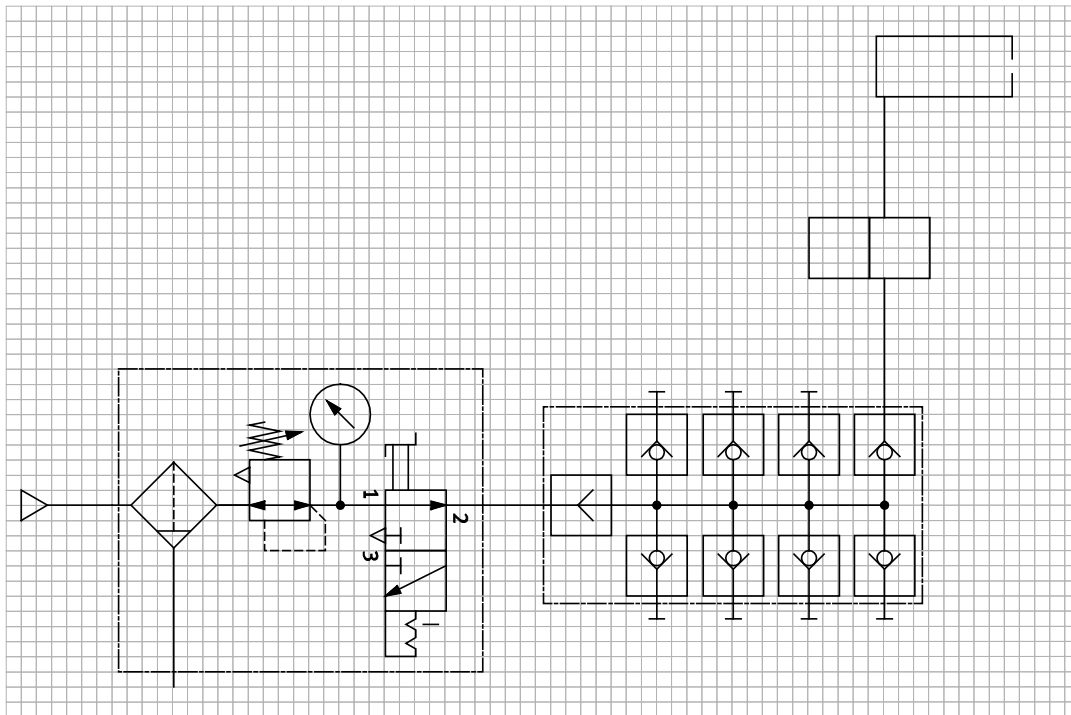

5. Creating the equipment list

- Create the equipment list. Enter the quantity, identification and designation of the required components in the table below.

Quantity	Identification	Designation
1		Distributor block
1		On-off valve with filter regulating valve
1	–	Compressed air source

6. Setting up the control system

Observe the following points when setting up the control system:

- Use the circuit diagram.
- Designate the components.
- Lay the compressed air tubing using the shortest routes possible.
- Push the compressed air tubing into the push-in connector as far as it will go.
- Mark the connected compressed air tubing on the circuit diagram.

7. Double-checking the control system setup

Observe the following points when commissioning the control system:

- Check all the tubing connectors.
- For the first test run, reduce the pressure on the filter regulating valve (service unit) to 350 kPa (3.5 bar).
- Switch on the compressed air supply at the service unit.
- Check that the control system is working correctly.
- Increase the pressure to the level specified in the exercise instructions.
- Allow the control system to run through several complete cycles.



Risk of injury when switching on the compressed air!

Cylinders may advance and retract automatically.

Risk of injury if compressed air tubing slips off!

If compressed air tubing slips off, shut off the compressed air supply immediately.

8. Describing the control system sequence

- Describe the individual steps of the control system sequence.

Initial position

Step 1-2

Step 2-3
